

POLYNOX BF

Crossflow beer filtration with polymeric membranes



D.E. free beer filtration with organic membranes

- Bright, yeast free filtered beer
- High flexibility for a wide range of beer types
- Easy to operate



The reliable solution for membrane filtration of beer

The technologies set up by Bucher Unipektin ensure performance, reliability, short return on investment and sound operating profits.

Bucher Unipektin, Competence Center Filtration, presents POLYNOX BF, the reliable solution for crossflow beer filtration with polymeric membranes.

- POLYNOX BF filtration process for high-quality filtered beer and steady flow rates.
- High filtrate yield without solid waste.
- Flexible automation system with maximum operational safety thanks to permanent self-controlling devices.
- Plants for batch and continuous operation available.
- Modular design for easy expansion.

Plant sizes from 10–500 hl/h.

Membranes

The filters are equipped with a polymeric, hydrophilic membrane with asymmetrical structure specially adapted to beer. The asymmetrical structure greatly contributes to maintaining a steady filtration flow rate. The membranes can be exposed to alkaline, acidic and oxidising cleaning agents for reliable recovery of filtration performance.

Process flow diagram

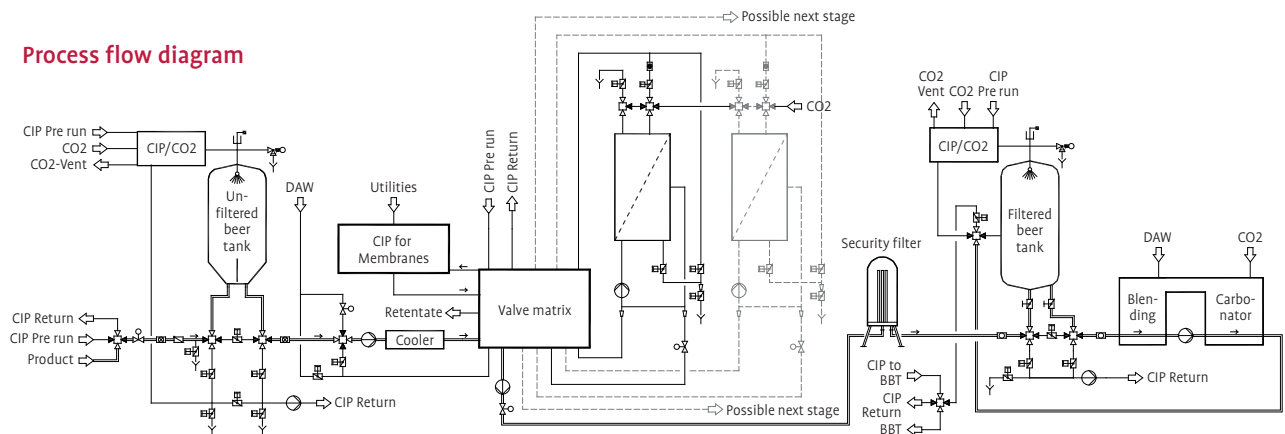

Bucher Unipektin AG

Competence Center Filtration
 Moosmühlestrasse 8
 CH-9000 St. Gallen
 Switzerland
 Phone +41 44 857 2900
 Fax +41 44 857 2990
 info.ccf@bucherunipektin.com
 www.bucherunipektin.com

Customer Service

Phone +41 44 857 29 00
 customer-service.ccf@bucherunipektin.com

Customer Service during Office Hours
 08:00–12:00 and 13:30–17:00 Swiss Time

Let's be clear!

Bucher Unipektin, Competence Center Filtration, is the world leading manufacturer of complete filtration solutions for the beverage industries. Our outstanding candle and horizontal leaf filters for the pre-coat filtration with kieselguhr and PVPP are the benchmark for the filtration of beer, sugar syrup, tea, gelatine and other liquid foods. We also develop and manufacture beer-recovery systems with ceramic membranes, crossflow membrane systems for beer main stream filtration, sterile filter systems with membrane cartridges and vacuum-distillation plants for de-alcoholisation.

Bucher Unipektin, Competence Center Filtration, is a business partner with a long-term industrial focus, committed to fair partnership with our customers, employees, and business associates.